



**Palstar Incorporated**  
9676 N. Looney Rd.,  
Piqua, OH 45356 USA  
**Customer Service and Sales Telephone:**  
1-800-773-7931  
**Fax:**  
1-937-773-8003  
**Email:**  
info@palstar.com

## **AT2K 2000 Watt Antenna Tuner**

---

# **Owner's Manual**

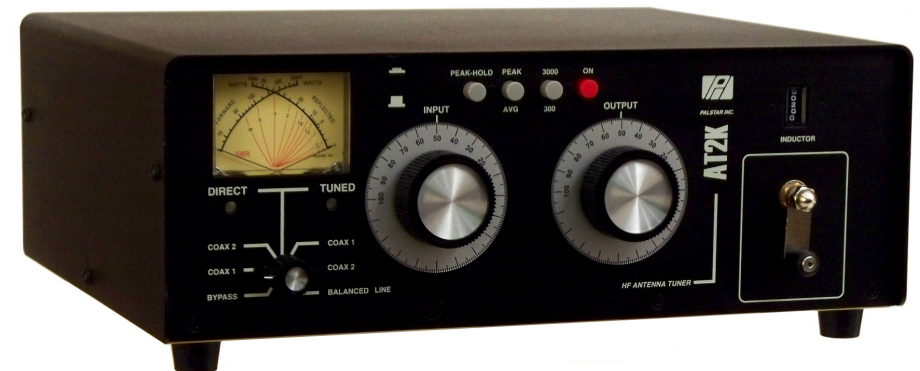

© Copyright 2010 Palstar Inc.  
Printed in the U.S.A.

**WARNING: TO PREVENT FIRE OR ELECTRICAL SHOCK DO NOT EXPOSE TO RAIN OR MOISTURE**



An appliance and cart combination should be moved with care. Quick stops, excessive force and uneven surfaces may cause the appliance and cart combination to overturn.



**WARNING: TO REDUCE THE RISK OF ELECTRIC SHOCK, DO NOT REMOVE COVER (OR BACK) NO USER-SERVICABLE PARTS INSIDE REFER SERVICING TO QUALIFIED PERSONNEL**



The lightning flash with arrow head symbol, within an equilateral triangle, is intended to alert the user to the presence of uninsulated "dangerous voltage" within the product's enclosure that may be of sufficient magnitude to constitute a risk of electric shock to persons.



The exclamation point within an equilateral triangle is intended to alert the user to the presence of important operating and maintenance (servicing) instructions in the literature accompanying the appliance.

**WARNING: TO REDUCE THE RISK OF FIRE OR ELECTRIC SHOCK, DO NOT EXPOSE THIS APPLIANCE TO RAIN OR MOISTURE. DO NOT OPEN THE CABINET WHILE OPERATING. REFER SERVICING TO QUALIFIED PERSONNEL ONLY.**

**CAUTION: TO PREVENT ELECTRIC SHOCK, DO NOT USE THE THREE WIRE CORD WITH AN EXTENSION CORD RECEPTACLE OR OTHER OUTLET UNLESS THE BLADES CAN BE FULLY INSERTED TO PREVENT BLADE EXPOSURE.**

**1. Read Instructions**—All the safety and operating instructions should be read before the appliance is operated.

**2. Retain Instructions**—The safety and operating instructions should be retained for future reference.

**3. Heed Warnings**—All warnings on the appliance should be adhered to.

**4. Follow Instructions**—All operating and use instructions should be followed.

**5. Cleaning**—Unplug this appliance from the wall outlet before cleaning. Do not use liquid cleaners or aerosol cleaners. Use a damp cloth for cleaning.

**6. Do Not Use Attachments**—not recommended by the manufacturer or they may cause hazards.

**7. Water and Moisture**—Do not use this product near water—for example, near a bathtub, wash bowl, kitchen sink, laundry tub, in a wet basement, or near a swimming pool—and the like.

**8. Accessories**—Do not place this product on an unstable cart, stand, tripod, bracket, or table. The product may fall, causing serious injury to a child or adult, and serious damage to the appliance.

**9. Ventilation**—This product should never be placed near or over a radiator or heat register. This product should not be placed in a built-in installation such as a bookcase or rack unless

proper ventilation is provided or the manufacturer's instructions have been adhered to. Any slots or openings in the cabinet are provided for ventilation. To ensure reliable operation of the video product and to protect it from overheating, these openings must not be blocked or covered. The openings should never be blocked by placing the product on a bed, sofa, rug, or other similar surface.

**10. Grounding or Polarization**—this product is equipped with a 3-wire line cord receptacle. It is intended for use with a 3-wire properly grounded power socket. Do not defeat the safety purpose of the supplied line cord and plug.

**11. Power Sources**—This product should be operated only from the type of power source indicated on the marketing label. If you are not sure of the type of power supplied to your home, consult your appliance dealer or local power company.

**12. Power-cord Protection**—Power-supply cords should be routed so they are not likely to be walked on or pinched by items placed upon or against them. Pay particular attention to cords at plugs, convenience receptacles, and the point where they exit.

**13. Lightning**—For added protection for this product during a lightning storm, or when it is left unattended and unused for long periods of time, unplug it from the wall outlet.

### Limited Warranty

Palstar Inc. warrants products manufactured by it to be free from defects in material and workmanship under normal use and service **for a period of one (1) year from the date of delivery to the first buyer** (the "Warranty Period"). Palstar Inc's obligation under this warranty is limited to repair or replacement of the product; at its option at the Palstar factory in Piqua, OH.

Effective only when the product is returned to the factory with all transportation charges prepaid and examination of the product discloses in Palstar's judgment, to have been defective during the Warranty Period.

The Warranty Period shall not extend beyond its original term with respect to interim in-warranty repairs by Palstar. This Warranty Period shall not apply to any product which has been repaired or altered by anyone other than Palstar without prior written authorization. Warranty does not extend to any products which have been subject to damage from improper installation, application or maintenance in accordance with the operating specification. Palstar neither assumes nor authorizes any person to assume for it any obligation or liability other than herein stated.

### Repair Policy

When sending in a product for service, please "double" box it carefully and ship it insured for your protection. Please include a note clearly describing the problem, how you wish the item returned and how you wish to pay for the service. Package your unit properly. Palstar, Inc. is not responsible for merchandise damaged in shipment. Our service rate is \$30 per hour (1/2 hr. minimum).

### Return Policy

All returns must receive prior authorization from Palstar. Returned items must be received in original—AS SHIPPED—condition including the original box, manuals, accessories, and copy of sales receipt. Returns must be within 14 days of purchase. Returned items are subject to a 25% restocking fee. Shipping is not refundable.

**14. Power Lines**—An outside antenna system should not be located in the vicinity of overhead power lines, other electric light or power circuits, where it can fall into such power lines or circuits. When installing an outside antenna system, extreme care should be taken to keep from touching such power lines or circuits as contact with them may be fatal.

**15. Overloading**—Do not overload wall outlets and extension cords as this can result in a risk of fire or electric shock.

**16. Object and Liquid Entry**—Never push objects of any kind into this product through openings as they may touch dangerous voltage points or short-out parts that could result in a fire or electric shock. Never spill liquid of any kind on the product.

**17. Servicing**—Do not attempt to service this product yourself as opening or removing covers may expose you to dangerous voltage or other hazards. Refer all servicing to qualified service personnel.

**18. Damage Requiring Service**—Unplug this product from the wall outlet and refer servicing to qualified service personnel under the following conditions:

- a. When the power-supply cord or plug is damaged.
- b. If liquid has been spilled, or objects have fallen into the product.
- c. If the product has been exposed to rain or water.
- d. If the product does not operate normally by following the operating instructions. Adjust only those controls that are covered by the operating instructions. An improper adjustment may result in damage and will often require extensive work by a qualified

technician to restore the product to its normal operation.

**e.** If the product has been dropped or the cabinet has been damaged.

**f.** When the product exhibits a distinct change in performance—this indicates a need for service.

**19. Replacement Parts**—when replacement parts are required, be sure the service technician has used replacement parts specified by the manufacturer or have the same characteristics as the original parts. Unauthorized substitutes may result in fire, electric shock or other hazards.

**20. Safety Checks**—Upon completion of any service or repairs to this product, ask the service technician to perform safety checks to determine that the product is in proper operating condition.

**21. Outdoor Antenna Grounding**—Before attempting to install this product, be sure the antenna or cable system is grounded so as to provide some protection against voltage surges and built-up static charges.

- a. Use No.10 AWG copper, No.8AWG aluminum, No.17AWB copper-clad steel or bronze wire or larger, as ground wire.
- b. Secure antenna lead-in and ground wires to house with stand-off insulators spaced from 4 feet to 6 feet apart.
- c. Mount antenna discharge unit as close as possible to where lead-in enters house.
- d. A driven rod may be used as the grounding electrode where other types of electrode systems do not exist. Refer to the National Electric Code, ANSI/NFPA 70-1990 for information.
- e. Use jumper wire not smaller than No.6 AWG copper or equivalent, when a separate antenna grounding electrode is used.

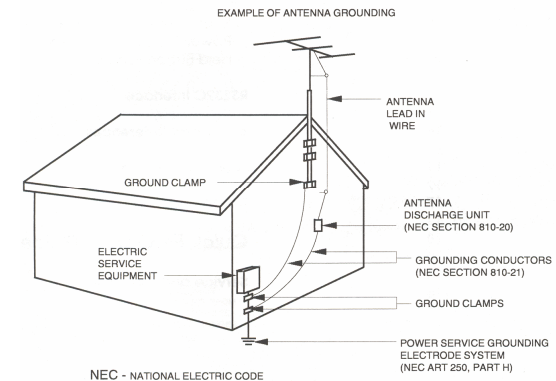

## 4 Table of Contents

Thank you for purchasing a Palstar AT2K Antenna Tuner. This antenna tuner has been designed and manufactured to high quality standards, and will provide reliable operation for many years.

Please carefully read the Owner's Manual in order to take advantage of the many interesting features that will provide years of enjoyable amateur radio operation.

<b>Important safeguards</b>	<b>2</b>
<b>Table of Contents</b>	<b>4</b>
<b>General Description</b>	<b>5</b>
<b>Installation</b>	<b>6</b>
Unpacking	6
Location	6
Installation Procedures	6
Rear Panel Connections	7
<b>Front Panel Description</b>	<b>8 &amp; 9</b>
<b>Schematic</b>	<b>10 &amp; 11</b>
<b>Operating Your AT2K</b>	<b>12</b>
Before Operating	12
Tuning	12
Beginning Settings Chart	12
Notes	13
<b>Specifications</b>	<b>14</b>
<b>Service and Warranty</b>	<b>15</b>
<b>Meter Board Adjustments</b>	<b>16</b>
<b>AT2K Internal Photo</b>	<b>17</b>
<b>User Notes</b>	<b>18</b>

## AT2K Internal Photo 17

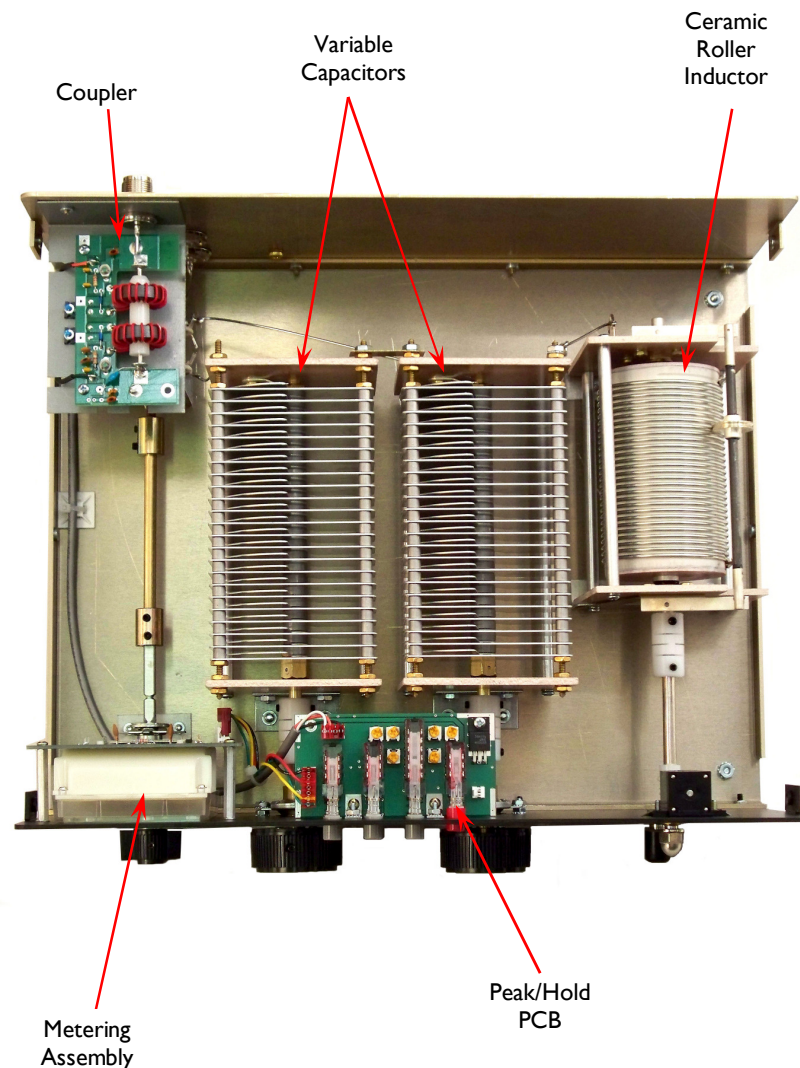

**Note: These adjustments control the calibration and accuracy of the AT2K metering. Do not adjust unless you are sure the metering is inaccurate, and you have accurate test equipment to check against.**

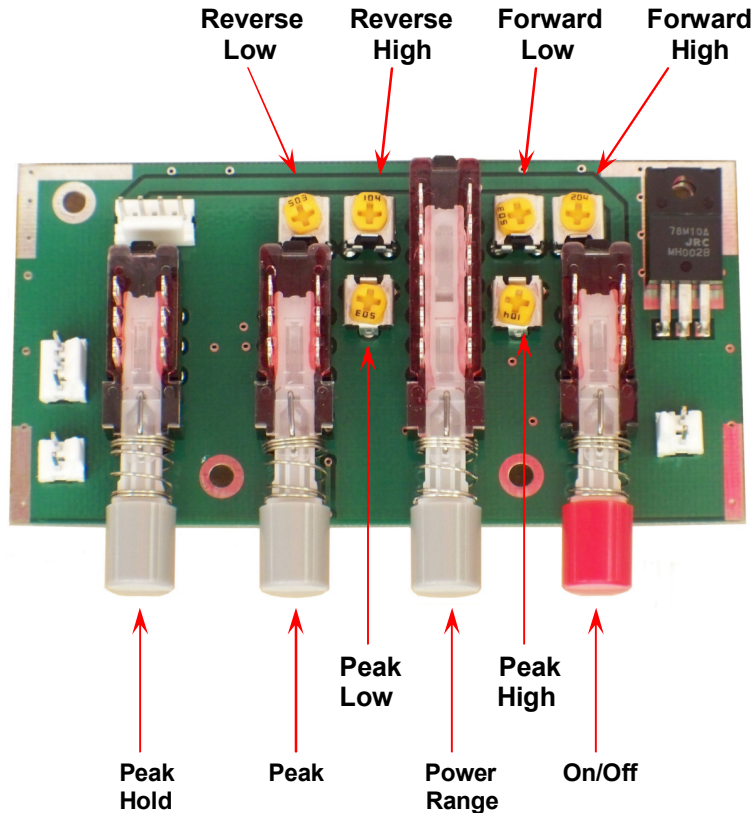

*Note: The adjustment pots on your meter board may differ in appearance from the photograph.*



Building on success, Palstar has upgraded the best-selling AT-1500CV throughout to create the American-made Palstar AT2K Antenna Tuner.

The AT2K optimizes the performance of your antenna and transmitter by providing adjustable impedance matching using a T-type circuit configuration.

The AT2K also measures the power (upgraded to include a PEAK/PEAK HOLD function) and Voltage Standing Wave Ratio (VSWR or SWR) which allows you to tune the SWR to the lowest ratio possible for the selected transmission frequency.

The AT2K also features a precision steatite ceramic core roller inductor with a silver plated roller wheel and roller shaft. It's new, smaller size permits operation on 6 meters.

A high voltage ceramic wafer switch allows selection between coax feedlines or wire-fed antennas. DIRECT switch positions bypass the impedance matching circuit but allow for the SWR, FORWARD, and REFLECTED and PEAK power meter FUNCTIONS.

Tuning is achieved with the front panel mounted controls. The 6:1 ratio Vernier dials allow for tuning with precision and accuracy, while the Inductor crank handle facilitates coarse adjustments.

The range of the meter (300W/3000W) is selected by a push button switch located on the front panel.

**Unpacking**

Carefully remove the AT2K from the shipping carton and inspect it for signs of damage. If any damage is apparent, notify the transportation carrier or dealer immediately. **We recommend keeping the packing carton for moving, storing or reshipping the tuner to us for repair if required.**

**Location**

Select a location for the AT2K that allows the connectors to be free from any possible contact with people, pets or objects during operation and with unrestricted air flow for cooling.

Connect coax cable(s) from your antenna to COAX 1 or COAX 2 connectors on the rear panel. These connectors are either direct from the transmitter or through the tuned circuit depending on the setting of the DIRECT/TUNED mode switch on the front panel.

Connect a dummy load to the BYPASS connector using a coax cable. This lets you select the dummy load from the DIRECT/TUNED mode switch. Any antenna that does not require the use of an antenna tuner may be connected to the BYPASS connector, if desired.



**WARNING: Balanced antennas will produce high RF voltages at the output post connectors. RF burns may result if touched during transmission.**

**Installation Procedures**

(See Figure 1 on next page.)

Connect a coax cable from your transmitter to the RF INPUT connector on the rear panel. Keep the cable as short as possible. If you use a linear amplifier, connect your transmitter to the linear amplifier input and the linear amplifier output to the AT2K. **Do not use more than 1500 watts average (single tone) through the tuner.**

**Front Panel Indicators and Controls**

Metering Dual movement cross needle power and frequency compensated coupler

**Controls**

Input & Antenna Tuning Variable capacitor 400 pF 4.5 KV 6:1 Vernier Drive

Inductance 25  $\mu$ H roller inductor; 12 ga. wire wound on steatite ceramic core, silver plated bar/wheel.

Antenna Selector Switch 6 position: Coax 1 tuned and tuner bypass  
Coax 2 tuned and tuner bypass  
Bypass and balanced antenna  
Switch wafers are (3kV rated)

Power Range Switch 2 position 300 W /3000 W

**Rear Panel Connectors**

RF INPUT SO-239 connector

Coax 1 SO-239 connector

Coax 2 SO-239 connector

Bypass SO-239 connector

Balanced Line COAX (Optional Balun)

End Fed Wire High Voltage Nylon66™ terminal post & ground post

12 VDC Input 14mm connector (2.1mm ID, 5.5mm OD, center positive, 200ma)

**Other**

Frequency Coverage 1.8 — 54 MHz

Power Maximum 2000 W PEP SSB, 1500 W single tone

Impedance Range 20 to 1500  $\Omega$  160 m to 10 m (assuming resistive load) Reduce power for lower Z range

Balanced Output 4:1 current type balun EXTERNAL-OPTIONAL

Dimensions 5" H x 14.5" W x 13.5" D (incl. terminals)

Weight 13 lbs.

Materials Chassis and top cover is 11 ga. (.090) aluminum that has been chem.-film treated. Front Panel powder coated and epoxy screened.

10. When you have tuned your antenna to the best SWR, record the settings of the INPUT, ANTENNA and INDUC-TANCE controls on the chart above for future reference. When you retune, use these settings as your starting point.

### Notes

1. An SWR of 1:1 is best, but an SWR as high as 2:1 may be acceptable. Check your transmitter/amplifier manual for details.

2. If you cannot get an acceptable SWR, lengthen or shorten your antenna and/or feedlines and retune.

3. If you get low SWR readings at more than one setting, use the setting that gives:

- highest Forward power reading
- lowest Reflected power reading
- uses the largest capacitance (highest number) on the INPUT and ANTENNA controls.

4. Any time a new or different antenna is connected, it is necessary to repeat the tuning procedure for each antenna.

5. Once every 4-6 months clean the roller coil with 70% isopropyl alcohol and a clean cotton cloth. **Do not remove the conducting grease on the rod that guides the roller wheel. Do not transfer any of the conducting grease from the rod to the roller coil body, as this will contaminate the windings.**

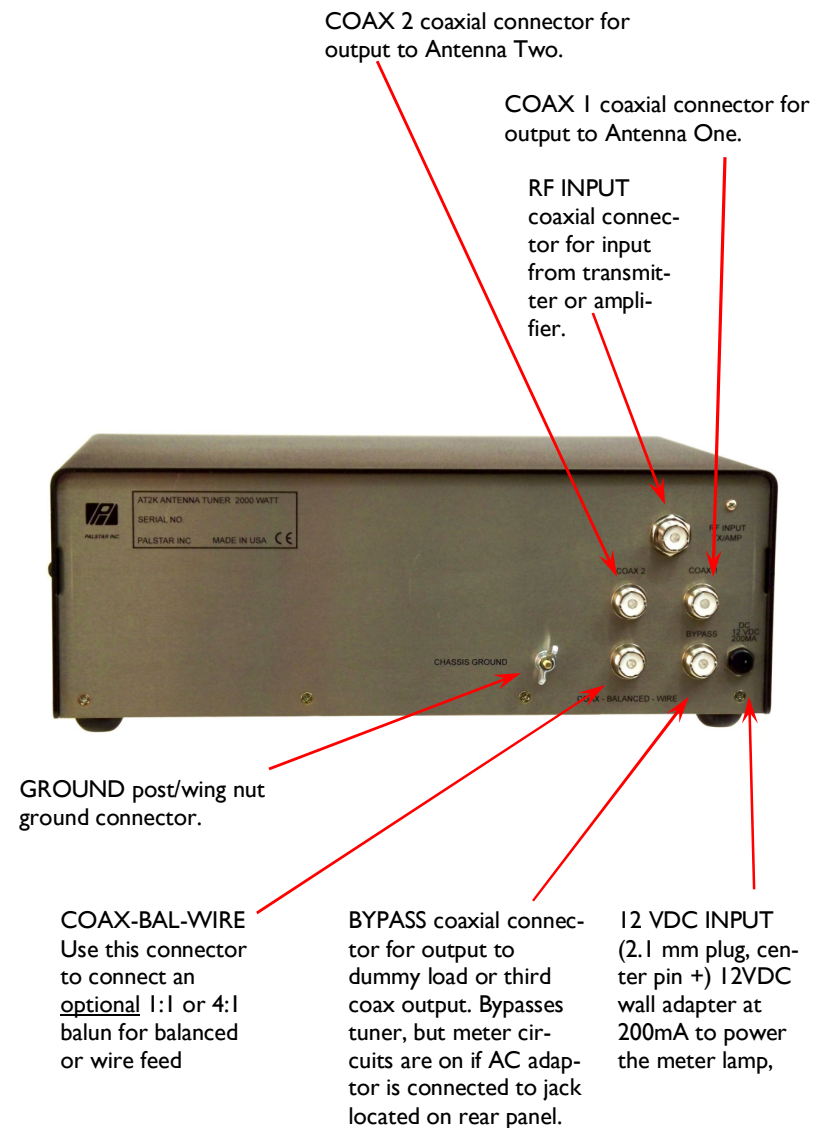

**FIGURE 1 — REAR PANEL CONNECTORS**

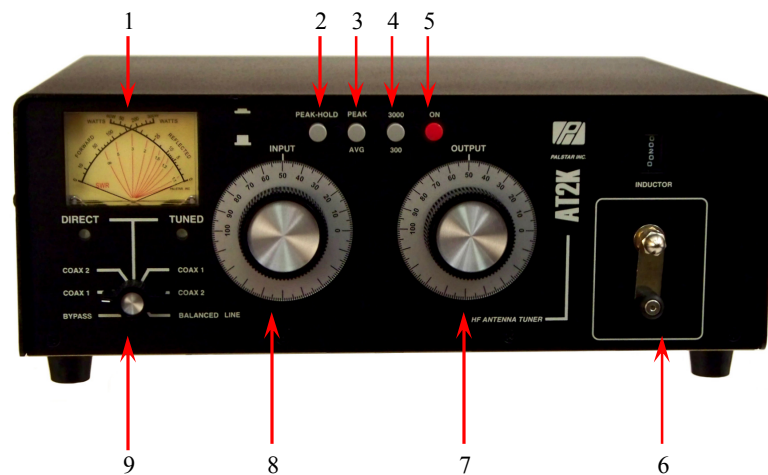

1. **POWER/SWR METER** Dual needle meter displays FORWARD and REFLECTED power in watts. SWR is measured where the two needles intersect on the red scale.
2. **PEAK HOLD** Select to read Peak Hold on the SWR meter. Peak switch [3] must be in PEAK position.
3. **PEAK** Selects between PEAK and AVERAGE Power metering display.
4. **RANGE** Two-position switch selects the range of FORWARD and REFLECTED power displayed on the power meter. When the RANGE button is OUT, the FORWARD meter scale reads 300 watts full scale and the REFLECTED meter scale reads 60 watts full scale. When the RANGE button is IN, the FORWARD meter scale reads 3000 watts full scale and the REFLECTED meter scale reads 600 watts full scale.
5. **ON** Select to turn on the backlight in the meter and enable metering, and 160 Meter functions. **The jack on the back panel must be supplied with 12 VDC for these functions to work.**
6. **INDUCTOR** 25  $\mu$ H continuously variable ceramic roller inductor driven by a crank handle. Coupled to the crank han-

**Do not exceed 1500 watts average (single tone).**

5. Set RANGE switch to 300 W (button out).
  6. Set the DIRECT/TUNED mode switch to the TUNED position matching your antenna connection. To tune your antenna, the switch selection must be set to: COAX 1 TUNED, COAX 2 TUNED or BALANCED LINE.
- Selecting COAX 1 DIRECT, COAX 2 DIRECT or BYPASS bypasses the tuning circuitry, and tuning is not possible.
7. Rotate the INPUT, ANTENNA and INDUCTOR controls for maximum noise or signal as heard on your receiver. Refer to preset tuning chart on page 12.

**CAUTION:** When approaching the end stops of the roller inductor, (readings of Zero or 279) **SLOW DOWN**. Slamming the roller wheel into the mechanical end stops on either end of the roller inductor can damage it.

8. Key your transmitter and adjust the power level for a reading of 50-100 watts on the FORWARD scale. Adjust the INPUT, OUTPUT and INDUCTOR controls for a minimum REFLECTED reading while maintaining a FORWARD reading of 50-100 watts using your transmitter power control.
9. Read the SWR on the red scale at the point where the two needles intersect. Repeat TUNING the input and antenna controls until the lowest SWR reading is obtained. The SWR should be 2:1 or lower.

*This procedure takes patience the first time. The input and antenna controls vary the capacitors and provide fine adjustments. The roller inductor crank control provides coarse adjustment.*



**Before Operating**

1. To avoid possible damage to the AT2K set INPUT, OUTPUT, INDUCTOR, and POWER RANGE switches as outlined in the chart below before applying transmitter power.
2. Begin tuning with your transmitter/amp feeding the tuner set at a low output power setting (50-100 Watts max).

**Tuning**



**WARNING: DO NOT OPERATE THE AT2K WITH THE COVER OFF.**

1. Select the band and frequency of desired operation.
2. Set TUNE and INDUCTOR controls to the suggested setting before applying transmitter power (see chart). Actual settings will vary from antenna. to antenna.
3. Set your transmitter/amplifier to a low power output. If your transmitter has a TUNE position, select that position.
4. If you use a linear amplifier, set it to Standby. Do not use the linear amplifier until the AT2K is tuned.

BAND	INPUT		OUTPUT		INDUCTOR	
	SUGGESTED	ACTUAL	SUGGESTED	ACTUAL	SUGGESTED	ACTUAL
160 M	50		65		32	
80 M	55		45		183	
40 M	45		56		239	
20 M	50		60		264	
17 M	50		60		267	
15 M	24		35		268	
12 M	24		35		271	
10 M	26		40		274	
6 M	40		30		265	

MIN = 279

dle is a gear-driven precision mechanical counter. The end stop readings on the turns counter are Zero and 279. Zero is maximum inductance, and 279 is minimum inductance.

7. **OUTPUT** Continuously adjustable output capacitor.
8. **INPUT** Continuously adjustable input capacitor.
9. **DIRECT-TUNED MODE SWITCH** Six-position rotary switch selects an output connector as follows—
  - a. **DIRECT BYPASS** selects BYPASS COAX CONNECTOR, bypassing the impedance matching circuit but providing SWR, FORWARD and REFLECTED power meter readings.
  - b. **DIRECT COAX 1** selects COAX 1 CONNECTOR, bypassing the tuner matching circuit but providing SWR, FORWARD and REFLECTED meter readings.
  - c. **DIRECT COAX 2** selects COAX 2 CONNECTOR, bypassing the tuner matching circuit but providing SWR, FORWARD and REFLECTED meter readings.
  - d. **TUNED COAX 1** selects COAX 1 CONNECTOR through the impedance matching T circuit.
  - e. **TUNED COAX 2** selects COAX 2 CONNECTOR through the impedance matching T circuit.

**AT2K ANTENNA TUNER**  
PALSTAR INC

