



44 Hancock Ave
Hamilton, Ohio 45011

www.jetstream-usa.com
800-524-4889

Instructions for JTG5RVSR

The Jetstream JTG5RVSR will work on 10-160 meters with an antenna tuner. You may install as a flat top or as an inverted V. The JTG5RVSR is fully assembled, just add any length of 50 ohm coax. It is recommended to wrap 8-10 turns of your coax in approximately 6" diameter coil close to the SO239 at the bottom of the ladderline.

When installing as an inverted V, the minimum angle should be 120 degrees.

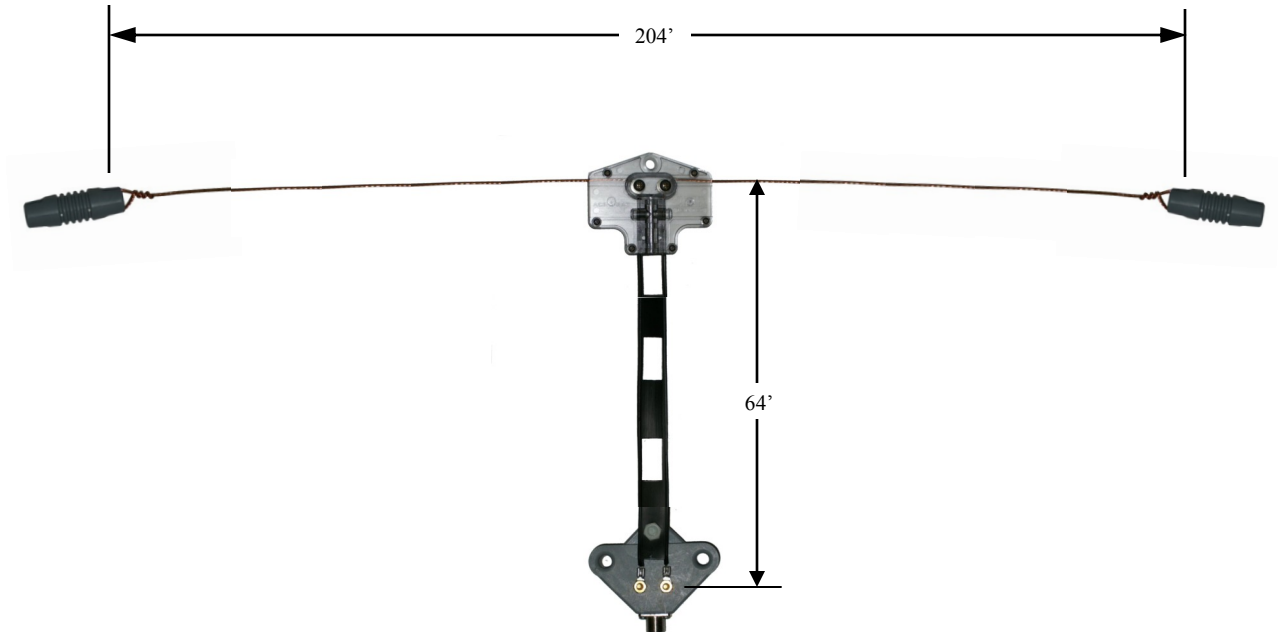

For best performance the antenna should be out in free space as much as possible. Do not allow any of the copper wire to touch any trees, etc. The ladder line should be at least 6" away from anything conductive. **DO NOT TAPE LADDERLINE TO THE LEG OF A TOWER.**

Specifications:

Max power: 2000 watts

Connector: SO239

Frequency range: 1.8-30 MHz with tuner

Recommended Accessories for the JTG5RVSR: Safety Instructions:

Lightning arrester: **Jetstream JT40R or JTLA1**

Coaxial Switch: **Jetstream CO201**

Coax: **Jetstream JT2008 RG8 type or JT1908 Mini 8 type**

If installing as a flat top and you do not have a center support, it is recommended to use JT1908 coax as it is lighter in weight than the JT2008.

Do not install on a rainy or windy day.

Do not install near power lines.

Do not install by yourself, always have someone else near by to help.

If antenna comes in contact with electric lines, do not try to remove. Call your electric company immediately.

If you do not have experience at installing antennas, seek the help of a professional.

www.jetstream-usa.com 800-524-4889